

# Network Management

SNMP, Disrupted

# The Problem(s)

---

- ▶ **On Earth, network management isn't too hard**
  - ▶ high speed, low latency, reliable links
  - ▶ guy paged at 4:00 AM; hops in van to go fix broken device
    - ▶ Turnaround: 24 – 48 hours
    - ▶ Cost: \$0.52 / mile (IRS rate) + off-hours pay
  
- ▶ **Space is a little harder**
  - ▶ variable speed, variable latency, generally unreliable links
  - ▶ guy paged at 4:00 AM; organizes mission to go fix broken device
    - ▶ Turnaround: 6 – 12 months
    - ▶ Cost: shuttle launch + entire team of specialists devoted to fixing issue + FTL drives + Bruce Willis



# Earthbound Solutions

---

- ▶ **SNMP : de-facto management standard on Earth**
  - ▶ Request / response
  - ▶ Some overhead involved
  - ▶ Not well suited to DTN operation
  
- ▶ **DING : SNMP += DTN**
  - ▶ Protocol we are in the process of defining and implementing
  - ▶ Scheduled data transmissions
  - ▶ “schemas” and “frames”
  - ▶ Schema : what to send; essentially a MIB (ASN.1 or SMIng)
  - ▶ Frame : data being sent



# Schema Format

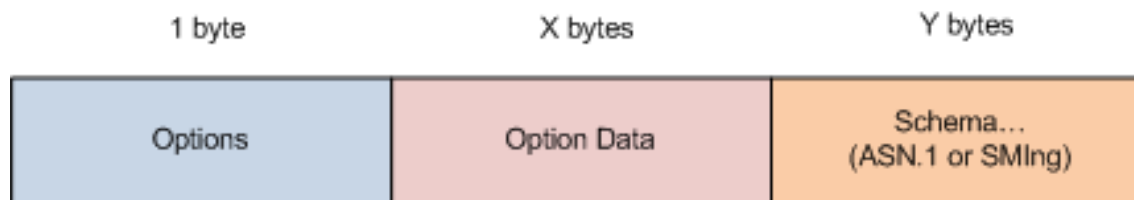

Schema payload format

Option Bits	
0	UID - Unique ID
1	LEN - Length (should equal Y)
2	GZP - GZIP'd schema
3	RMV - Remove schema (UID req'd)
4	SEC - Security enabled (Need SHA/MD5/EXT)
5	SHA - Use SHA-1 hash
6	MD5 - Use MD5 hash
7	EXT - Extended options (SDNV len -> opt data)

# Data (Frame) Format

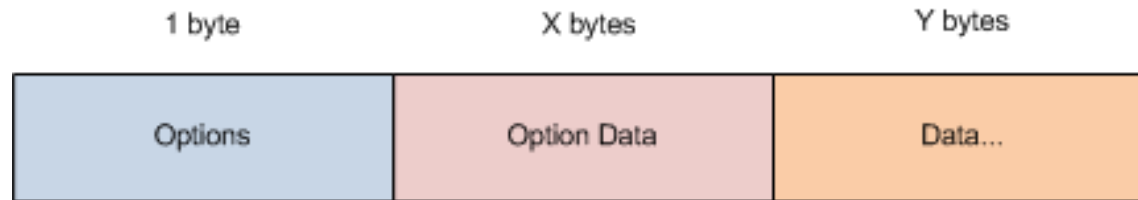

Data payload format

Option Bits	
0	UID - Unique ID
1	LEN - Length (should equal Y)
2	GZP - GZIP'd schema
3	RMV - Remove schema (UID req'd)
4	SEC - Security enabled (Need SHA/MD5/EXT)
5	SHA - Use SHA-1 hash
6	MD5 - Use MD5 hash
7	EXT - Extended options (SDNV len -> opt data)

# Room for Improvement

---

- ▶ **Need a way to set values**
  - ▶ Haven't figured out a good way to do that as of yet
- ▶ **Out of order schema + data delivery is a problem**
  - ▶ Only an issue for writing data to remote hosts
  - ▶ Schema to interpret data may arrive a year after the data does
    - ▶ Seems a waste to discard data, though
- ▶ **Implementation issues**
  - ▶ Writing this application using the SimpleBP API developed here
  - ▶ First semi-major application of said API, so discovering new features every day!



# Playing Nicely with Others

---

- ▶ DING seems to work reasonably well over DTN so far
  - ▶ However, neither design nor implementation == done
- ▶ However, everybody on Earth uses SNMP
  - ▶ DING isn't really all that famous (yet?)
- ▶ We should provide a way for data transmitted by DTN hosts using DING to be accessed through SNMP
  - ▶ We need a gateway!



# Playing Nicely with Others (cont)

---

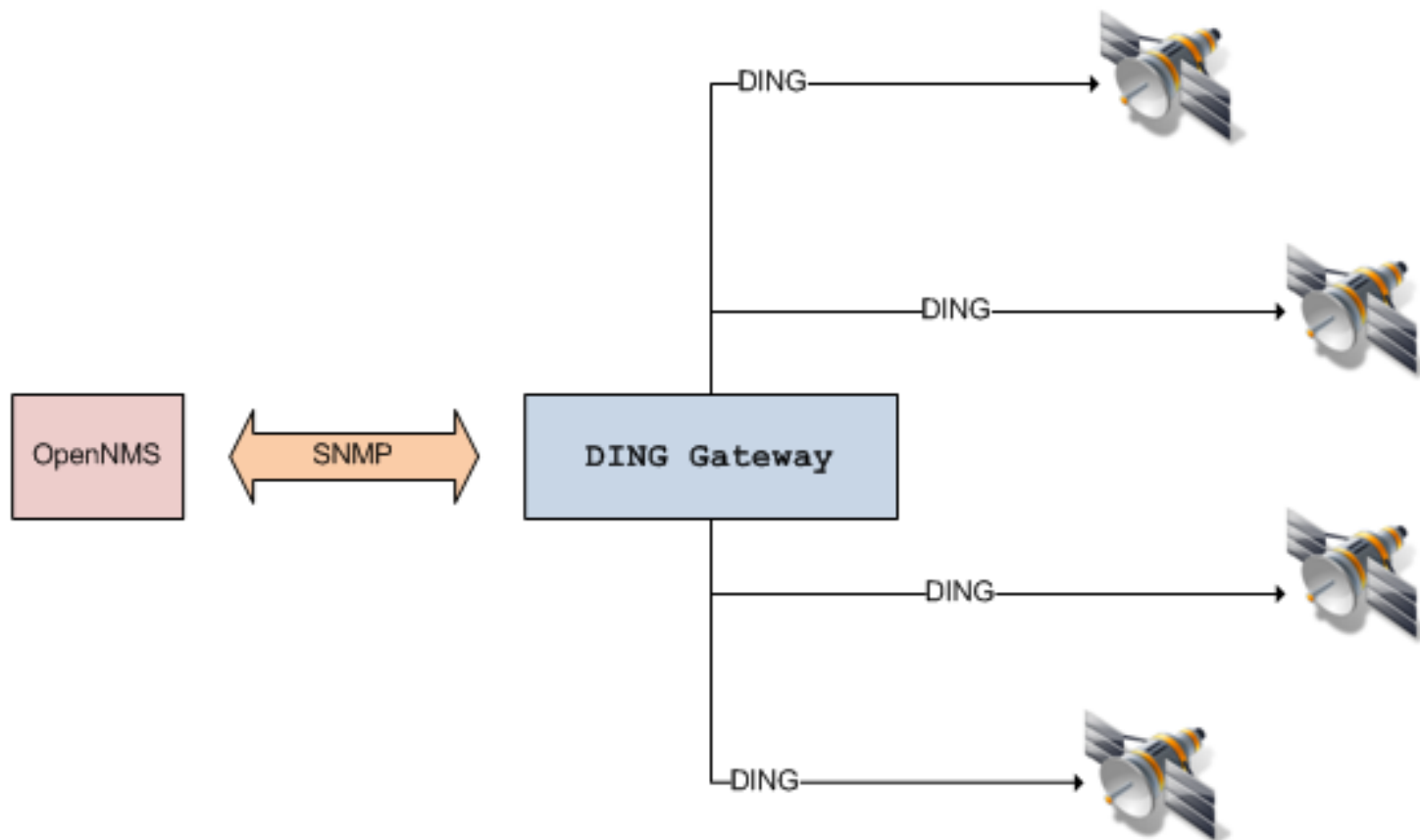

# DING Gateway (Internals)

---

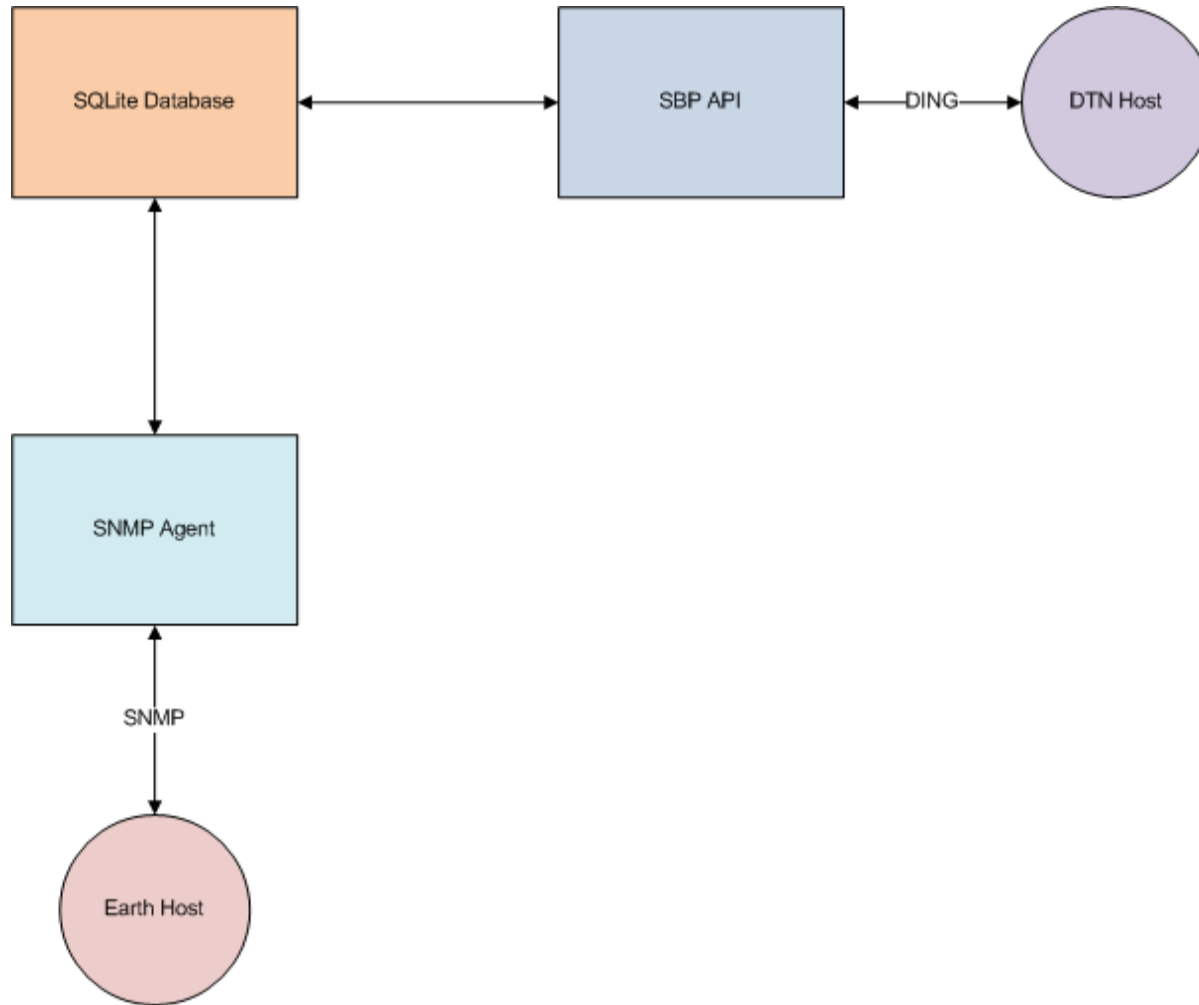

# SNMP Proxy

---

- ▶ **Answers queries on behalf of DTN nodes**
  - ▶ Must keep track of all managed nodes
- ▶ **Must parse incoming SNMP messages**
  - ▶ “Destination” must be encapsulated in the SNMP PDU
    - ▶ How? SNMPv3 ContextName
- ▶ **Must have intimate knowledge of database**
  - ▶ Keeps a mapping between MIB and DING data structures



# SNMP Agent Setup

---

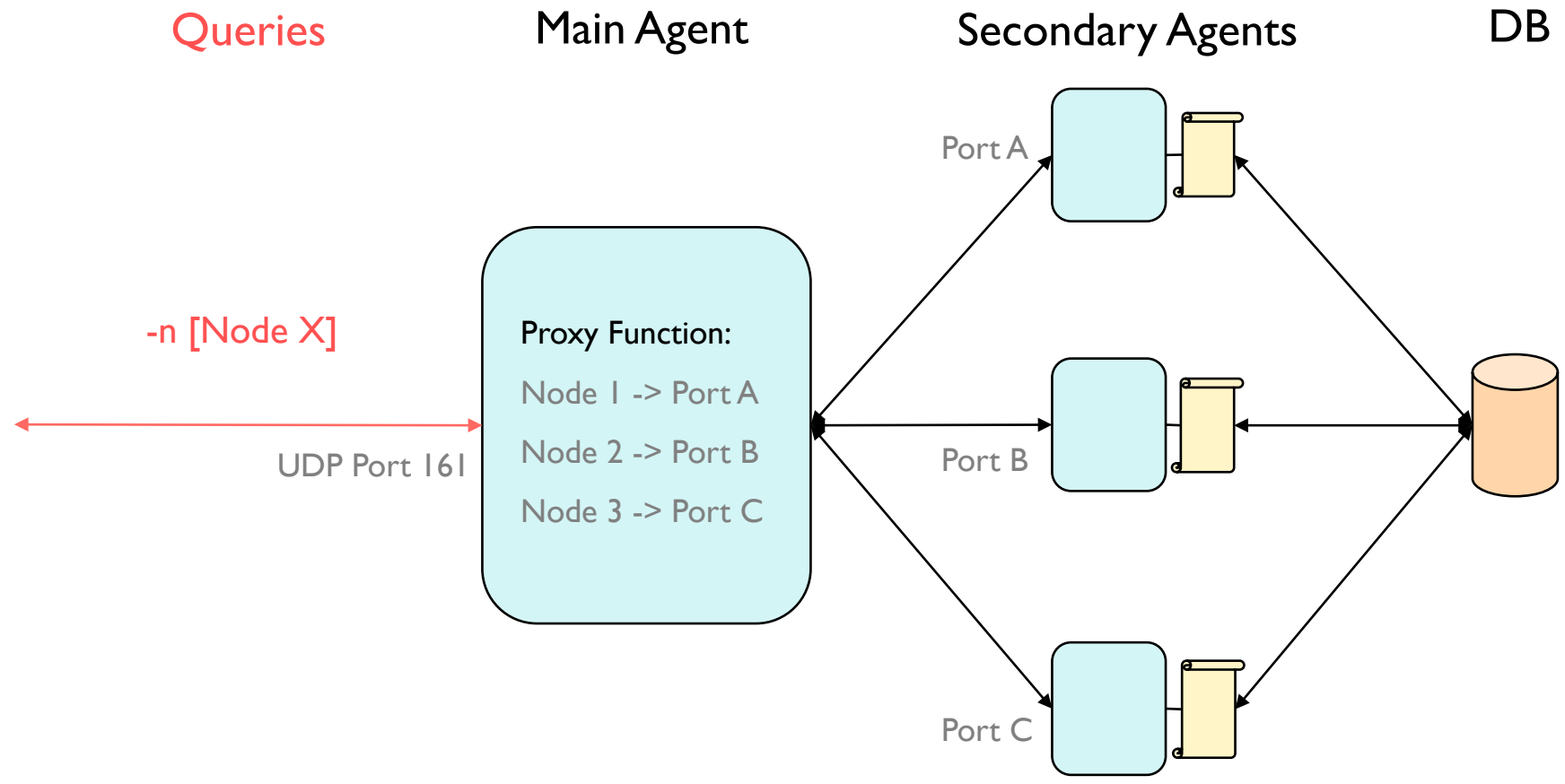

# SNMP Proxy: Current and Future Status

---

## ▶ Now

- ▶ Barebones MIB: STATTRACKER-MIB::stattrackerMIB
- ▶ Query-able data: endpoints, outducts, and memory usage
- ▶ Responds to snmpwalk and snmpget

## ▶ Future

- ▶ Full ION MIB
- ▶ snmpset
- ▶ User-friendly scripts for adding managed nodes
- ▶ Integration with management station (e.g. OpenNMS)



# Our Progress

---

- ▶ **Working status updates via DTN**
  - ▶ DING v0.01 alpha
  - ▶ Bundles sent with SBP API
  - ▶ Can show sample usage upon request
  - ▶ Live demo! (<http://nerys.its.ohiou.edu/dtnstat/>)
    - ▶ Note that that link points to a development server
    - ▶ Code / content will not be stable and / or necessarily always up
- ▶ **Working DING gateway**
  - ▶ SNMP server running on nerys.its.ohiou.edu that will provide information on any host it has received an update from
  - ▶ Live demo!



# Questions / Comments

---

- ▶ Questions / comments / discussion welcome!
- ▶ Thanks for listening!

